

A woman with long, wavy brown hair and aviator sunglasses is looking directly at the camera. She is holding a small, green and blue globe of the Earth in her hands. She is wearing a dark, long-sleeved jacket. The background is a modern building with a grid-like facade of windows, some of which are reflecting the sky. The sky is a pale, clear blue. The overall mood is contemplative and futuristic.

2097

WE MADE OURSELVES OVER

Our Ambition

To create a science fiction event that engages its audiences in a story which is citywide and speculates a vision of the world in 80 years time.

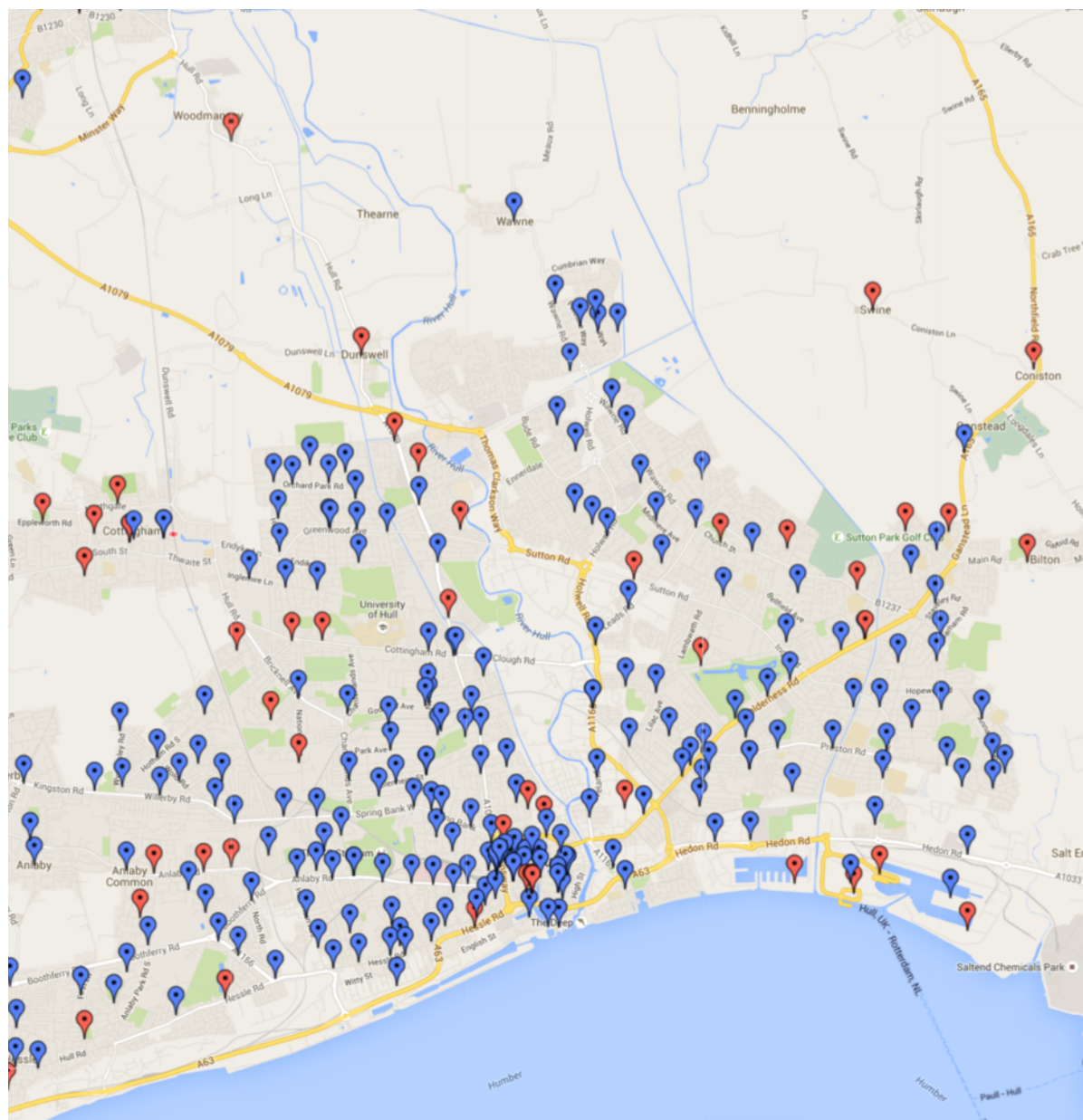

Our Ambition

To create a science fiction event that engages its audiences in a story which is citywide and speculates a vision of the world in 80 years time.

Taking place over ten weeks, using phone boxes, intimate face to face encounters with players across the city, an app for smartphones, and a series of five extraordinary films.



Our Ambition

To create a science fiction event that engages its audiences in a story which is citywide and speculates a vision of the world in 80 years time.

Over ten weeks, using phone boxes, an app for smartphones, intimate face to face encounters with players across the city and a series of five extraordinary films using VFX to merge Aarhus and Hull in a combined future city.

A digital strategy that will cast the conversations in the city out to the web and social platforms, developing conversations there that lead to the premieres of the films online.

Regional Multimedia Publisher Of the Year 2008 & 2009 Visit our website thisishull.co.uk

BLITZ
REPLICA EDITION
INSIDE TODAY

HULL DAILY MAIL
At the heart of all things local since 1885 Friday May 6 2011 40p

Summer Bedding
Grown On Our Own Nursery
12 Pack £2.95 - 24 Pack £3.95
COLETTA & TYSON
324 Hull Road, Woodmansey 01482 265410
www.colettatagardencentre.co.uk

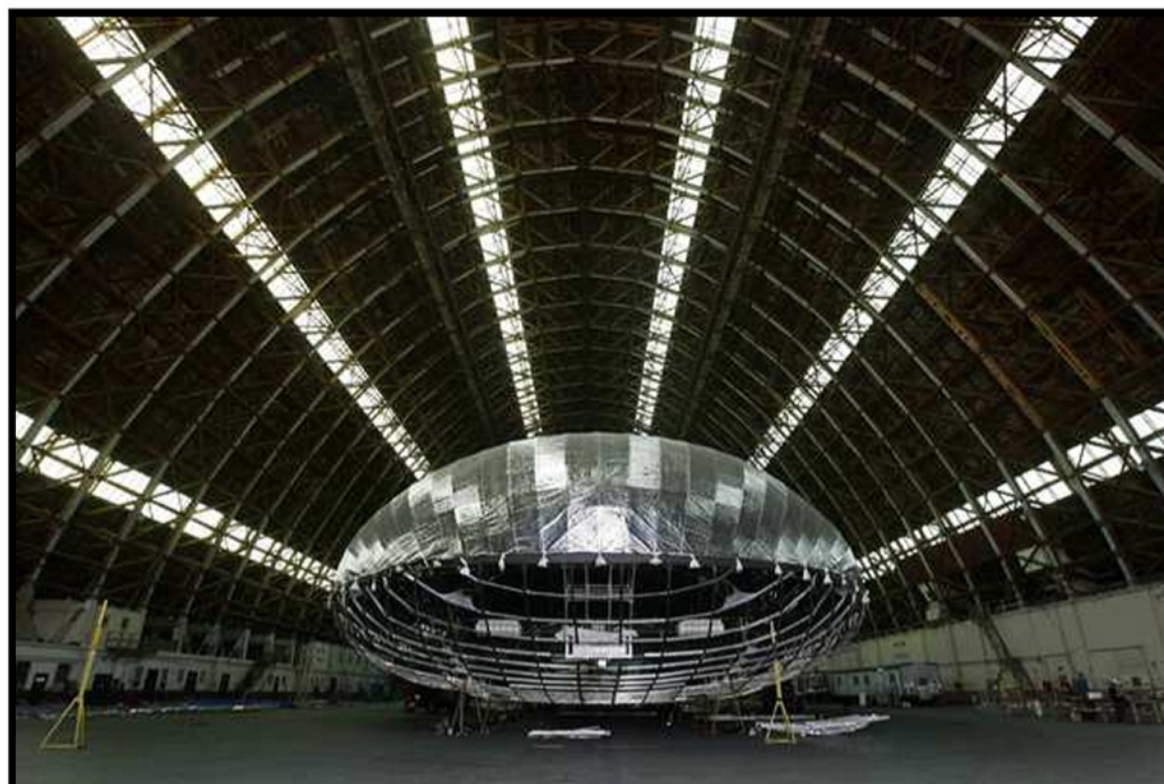

**HULL HOME TO
UK SPACEPORT**

**LIGHTER THAN AIR
CARGO SHIP BEGINS
OPERATING IN AUGUST**



The Process

Blast Theory will engage with diverse groups from around Hull, including schools, youth groups and community organisations, and work with experts from the University of Hull to reimagine the city in the year 2097.

Local people and participants from the workshops will be invited to take part as cast members and enlisted to suggest film locations.



The Films + Screenings

The films will be short, shareable and provocative using visual effects to bring the future city to life; showing familiar locations and landmarks from diverse neighbourhoods in Hull in a dramatic new light.

A specially adapted truck will tour the city to screen the films during the ten weeks. Acting as a projection platform, the truck will turn walls and billboards across the city into temporary screens.



Phone boxes

Phone boxes across the city will become portals to the future.

Every fortnight, every phone box across the city will ring simultaneously to announce the release of a new film. Pick up the call when the phone boxes ring, or call from any phone box during the ten weeks and at the end of the line is a character from 2097 asking for your help.



Face to face encounters

Over five weekends, callers from the city's phone boxes will have the chance to be picked up by one of a fleet of anonymous blacked out electric cars that will appear gliding back and forth across the city.

These become the mobile setting for the public to reflect on the story and share their visions of the future.



Smartphones

To accompany each film, an interactive video will be released for smartphone users. Framed Facetime style, each interactive video will feature a character from one of the films, allowing you to interact with them and inviting you to help decide their future.

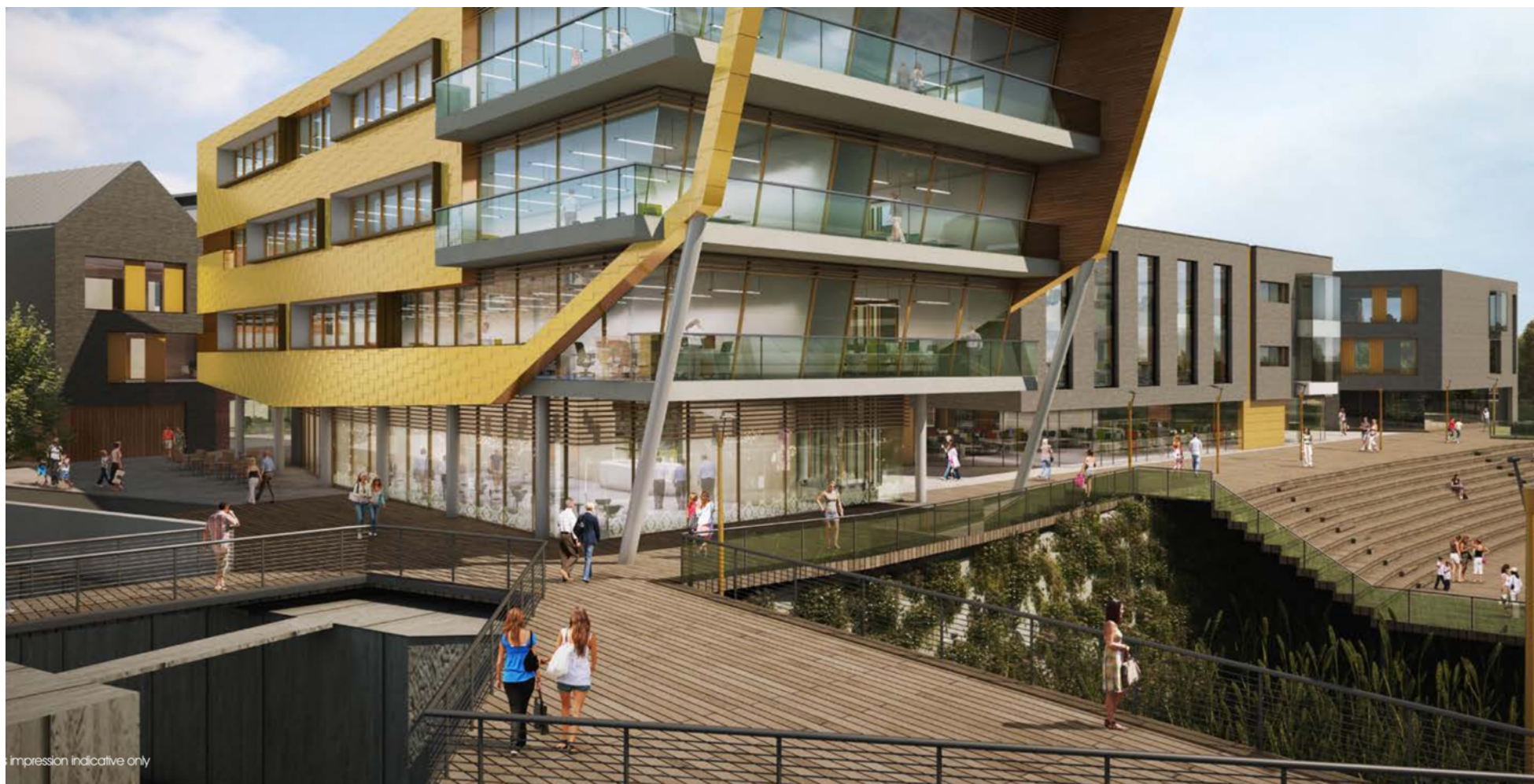

The Finale

The ten weeks concludes with a celebratory finale at @TheDock in the Fruit Market. An outdoor screening of all five films will be complemented with contributions from participants in the workshop process and videos from the past ten weeks.

Kcom Integration

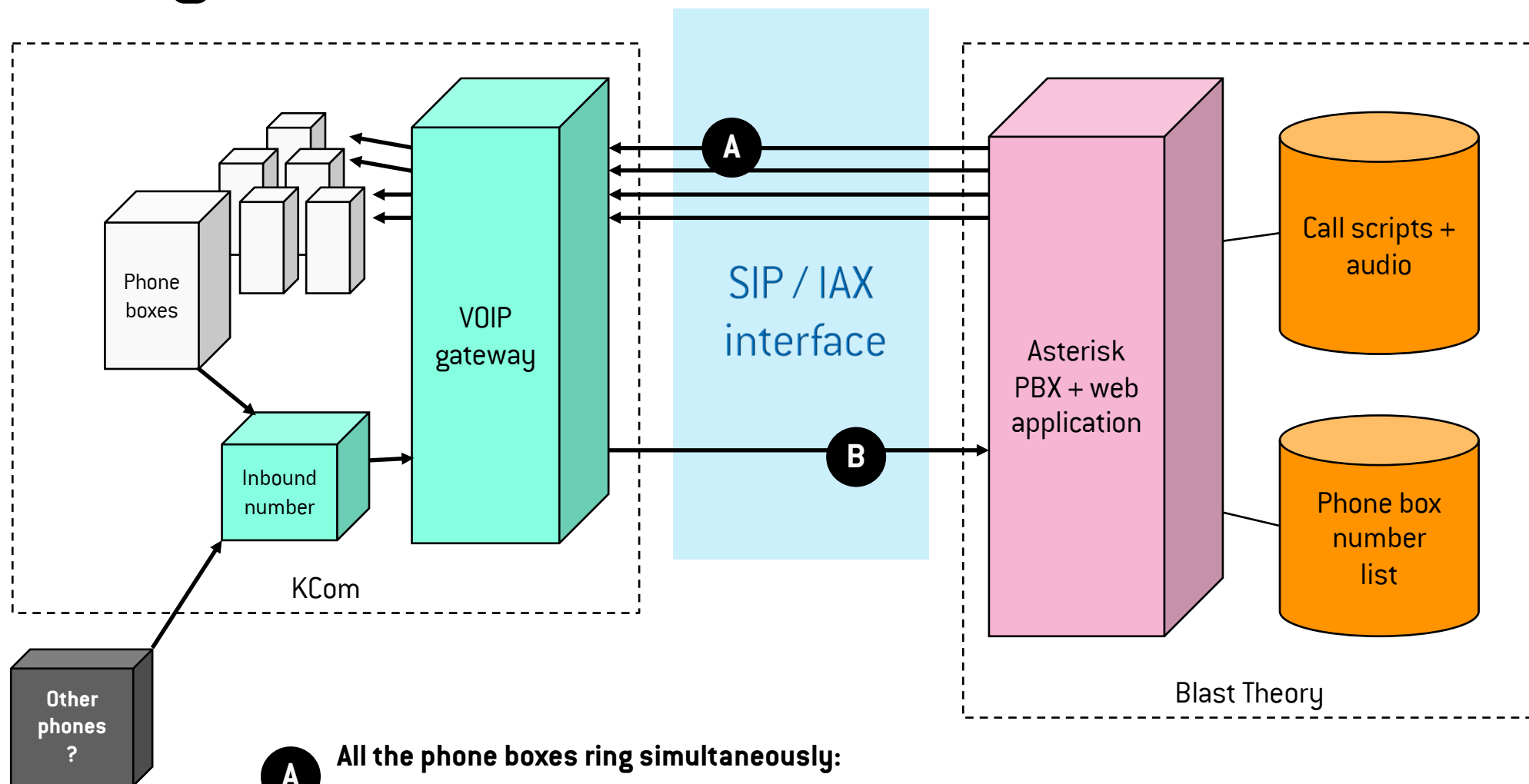

- A All the phone boxes ring simultaneously:**
Multiple SIP/IAX requests to initiate a call to each phone box on network
- B Individual callers phone in:**
Individual SIP/IAX requests are forwarded to Blast Theory's PBX